

SP DOSS 1/50

Type: Pendant lamp

Material: chinz fabric, powder coating steel.

Dimension: d.50 H26cm (lampshade) max elevation 150cm

Certification: CE | Class 1 | I P20

Packaging: 0,52 x 0,52 x 0,39mt

Weight: 4kg

Product code: SPDOSS1/50

Source: 1 x E27 led bulb 9W (not included)

Color temperature tolerance: -

Luminous flux, Lm: -

Color: -

Power consumption: 9Watt

dimnable sistem: on/off (dimnable with dimnable led bulbs)

Energy class: A++

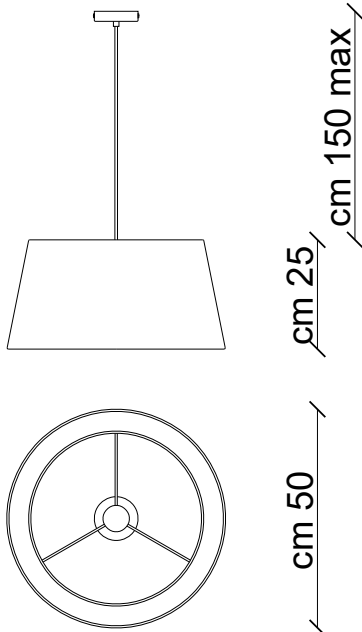

Fabric: chinz fabric



Cable:

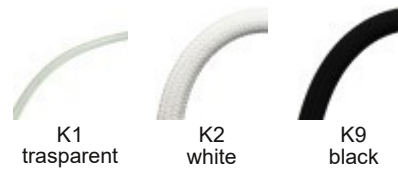

Metal finish powder coating



Cleaning instruction: Clean with a soft dry cloth only. Do not use polishing agents, water or abrasive materials when cleaning. Always switch off the electricity supply before cleaning.

Made in Croatia

Lika light is a trademark owned by Lika svjetlo d. o. o.